

CODE

B



# NARAYANA

## IIT/PMT ACADEMY

### CBSE MAINS-2011 QUESTIONS PAPER WITH KEY

### CHEMISTRY

1. Which of the following is not a fat soluble vitamin?

- (1) Vitamin B complex      (2) Vitamin D  
(3) Vitamin E                (4) Vitamin A

Ans. (1)

2. Which of the statements about "Denaturation" given below are correct?

- (a) Denaturation of proteins causes loss of secondary and tertiary structures of the protein  
(b) Denaturation leads to the conversion of double strand of DNA into single strand  
(c) Denaturation affects primary structure which gets distorted

- (1) (b) and (c)                (2) (a) and (c)  
(3) (a) and (b)                (4) (a), (b) and (c)

Ans. (3)

3. Which has the maximum number of molecules among the following?

- (1) 44 g CO<sub>2</sub>                (2) 48 g O<sub>3</sub>  
(3) 8 g H<sub>2</sub>                    (4) 64 g SO<sub>2</sub>

Ans. (3)

4. The half life of a substance in a certain enzyme-catalysed reaction is 138 s. The time required for the concentration of the substance to fall from 1.28 mg L<sup>-1</sup> to 0.04 mg L<sup>-1</sup>, is

- (1) 414 s                        (2) 552 s  
(3) 690 s                        (4) 276 s

Ans. (3)

5. Which of the following compounds undergoes nucleophilic substitution reaction most easily

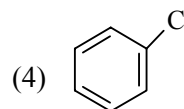
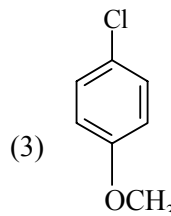
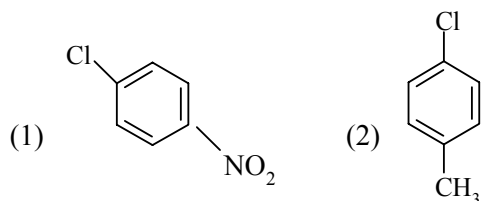

Ans. (1)

6. Which of the following statements is incorrect?

- (1) Pure sodium metal dissolves in liquid ammonia to give blue solution  
(2) NaOH reacts with glass to give sodium silicate  
(3) Aluminium with excess NaOH to give Al(OH)<sub>3</sub>  
(4) NaHCO<sub>3</sub> on heating gives Na<sub>2</sub>CO<sub>3</sub>

Ans. (3)

7. A 0.1 molal aqueous solution of a weak acid is 30% ionized. If K<sub>f</sub> for water is 1.86°C/m, the freezing point of the solution will be

- (1) -0.18°C                    (2) -0.54°C  
(3) -0.36°C                    (4) -0.24°C

Ans. (4)

8. The rate of the reaction  $2\text{N}_2\text{O}_5 \rightarrow 4\text{NO}_2 + \text{O}_2$  can be written in three ways

$$-\frac{d[\text{N}_2\text{O}_5]}{dt} = k[\text{N}_2\text{O}_5]$$

$$\frac{d[\text{NO}_2]}{dt} = k'[\text{N}_2\text{O}_5]$$

$$\frac{d[\text{O}_2]}{dt} = k''[\text{N}_2\text{O}_5]$$

The relationship between k and k' and between k and k'' are

- (1) k' = 2k ; k'' = k                (2) k' = 2k ; k'' = k/2  
(3) k' = 2k ; k'' = 2k                (4) k' = k ; k'' = k

Ans. (2)

9. Which of the following carbonyls will have the strongest C – O bond?

- (1)  $\text{Mn}(\text{CO})_6^+$  (2)  $\text{Cr}(\text{CO})_6$   
 (3)  $\text{V}(\text{CO})_6^-$  (4)  $\text{Fe}(\text{CO})_5$

Ans. (3)

10. The order of reactivity of phenyl magnesium bromide ( $\text{PhMgBr}$ ) with the following compounds

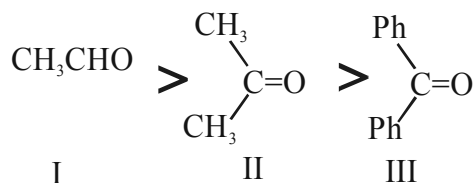

- (1) III > II > I (2) II > I > III  
 (3) I > III > II (4) I > II > III

Ans. (4)

11. The IUPAC name of the following compound

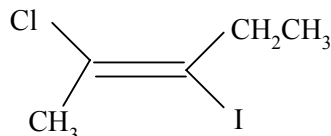

- (1) trans-2-chloro-3-iodo-2-pentene  
 (2) cis-3-iodo-4-chloro-3-pentene  
 (3) trans-3-iodo-4-chloro-3-pentene  
 (4) cis-2-chloro-3-iodo-2-pentene

Ans. (1)

12. According to the Bohr Theory, which of the following transitions in the hydrogen atom will give rise to the least energetic photon?

- (1)  $n = 6$  to  $n = 1$  (2)  $n = 5$  to  $n = 4$   
 (3)  $n = 6$  to  $n = 5$  (4)  $n = 5$  to  $n = 3$

Ans. (3)

13. A solid compound XY has NaCl structure. If the radius of the cation is 100 pm, the radius of the anion ( $\text{Y}^-$ ) will be

- (1) 275.1 pm (2) 322.5 pm  
 (3) 241.5 pm (4) 165.7 pm

Ans. (3)

14. Consider the following processes

	$\Delta H$ (kJ/mol)
$1/2 \text{A} \rightarrow \text{B}$	+ 150
$3\text{B} \rightarrow 2\text{C} + \text{D}$	– 125
$\text{E} + \text{A} \rightarrow 2\text{D}$	+ 350

For  $\text{B} + \text{D} \rightarrow \text{E} + 2\text{C}$ ,  $\Delta H$  will be

- (1) 525 kJ/mol (2) – 175 kJ/mol  
 (3) – 325 kJ/mol (4) 325 kJ/mol

Ans. (2)

15. Match the compounds given in List – I with List – II and select the suitable option using the code given below.

List – I		List – II	
(a)	Benzaldehyde	(i)	Phenolphthalein
(b)	Phthalic anhydride	(ii)	Benzoin Condensation
(c)	Phenyl benzoate	(iii)	Oil of wintergreen
(d)	Methyl salicylate	(iv)	Fries rearrangement

Code:

	(a)	(b)	(c)	(d)
(1)	(iv)	(i)	(iii)	(ii)
(2)	(iv)	(ii)	(iii)	(i)
(3)	(ii)	(iii)	(iv)	(i)
(4)	(ii)	(i)	(iv)	(iii)

Ans. (4)

16. Which of the following compounds is most basic?

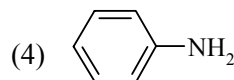
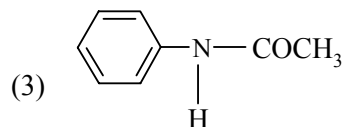
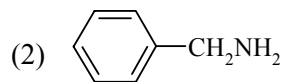
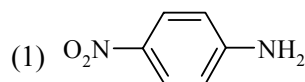

Ans. (2)

17. Which of the following structures is the most preferred and hence of lowest energy for  $\text{SO}_3$ ?

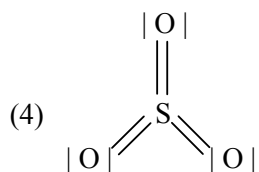
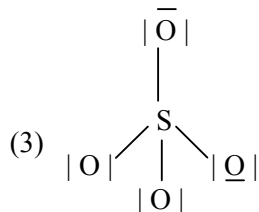
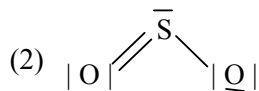
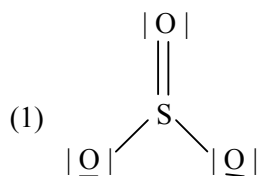

Ans. (4)

18. A solution contains  $\text{Fe}^{2+}$ ,  $\text{Fe}^{3+}$  and  $\text{I}^-$  ions. This solution was treated with iodine at  $35^\circ\text{C}$ .  $E^\circ$  for  $\text{Fe}^{3+}/\text{Fe}^{2+}$  is  $+0.77\text{ V}$  and  $E^\circ$  for  $\text{I}_2/2\text{I}^- = 0.536\text{ V}$ . The favourable redox reaction is

- (1)  $\text{I}_2$  will be reduced to  $\text{I}^-$
- (2) There will be no redox reaction
- (3)  $\text{I}^-$  will be oxidised to  $\text{I}_2$
- (4)  $\text{Fe}^{2+}$  will be oxidised to  $\text{Fe}^{3+}$

Ans. (3)

19. What is the value of electron gain enthalpy of  $\text{Na}^+$  if  $\text{IE}_1$  of  $\text{Na} = 5.1\text{ eV}$ ?

- (1)  $-5.1\text{ eV}$
- (2)  $-10.2\text{ eV}$
- (3)  $+2.55\text{ eV}$
- (4)  $+10.2\text{ eV}$

Ans. (1)

20. The unit of rate constant for a zero order reaction is

- (1)  $\text{mol L}^{-1} \text{s}^{-1}$
- (2)  $\text{L mol}^{-1} \text{s}^{-1}$
- (3)  $\text{L}^2 \text{mol}^{-2} \text{s}^{-1}$
- (4)  $\text{s}^{-1}$

Ans. (1)

21. In qualitative analysis, the metals of Group I can be separated from other ions by precipitating them as chloride salts. A solution initially contains  $\text{Ag}^+$  and  $\text{Pb}^{2+}$  at a concentration of  $0.10\text{ M}$ . Aqueous  $\text{HCl}$  is added to this solution until the  $\text{Cl}^-$  concentration is  $0.10\text{ M}$ . What will be concentrations of  $\text{Ag}^+$  and  $\text{Pb}^{2+}$  be at equilibrium?

( $K_{\text{sp}}$  for  $\text{AgCl} = 1.8 \times 10^{-10}$ ,  $K_{\text{sp}}$  for  $\text{PbCl}_2 = 1.7 \times 10^{-5}$ )

- (1)  $[\text{Ag}^+] = 1.8 \times 10^{-7}\text{ M}$ ;  $[\text{Pb}^{2+}] = 1.7 \times 10^{-7}\text{ M}$
- (2)  $[\text{Ag}^+] = 1.8 \times 10^{-11}\text{ M}$ ;  $[\text{Pb}^{2+}] = 8.5 \times 10^{-5}\text{ M}$
- (3)  $[\text{Ag}^+] = 1.8 \times 10^{-9}\text{ M}$ ;  $[\text{Pb}^{2+}] = 1.7 \times 10^{-3}\text{ M}$
- (4)  $[\text{Ag}^+] = 1.8 \times 10^{-11}\text{ M}$ ;  $[\text{Pb}^{2+}] = 1.7 \times 10^{-7}\text{ M}$

Ans. (3)

22. A bubble of air is underwater at temperature  $15^\circ\text{C}$  and the pressure  $1.5\text{ bar}$ . If the bubble rises to the surface where the temperature is  $25^\circ\text{C}$  and the pressure is  $1.0\text{ bar}$ , what will happen to the volume of the bubble?

- (1) Volume will become greater by a factor of 1.6
- (2) Volume will become greater by a factor of 1.1.
- (3) Volume will become smaller by a factor of 0.70
- (4) Volume will become greater by a factor of 2.5

Ans. (1)

23. Match List – I and List – II for the composition of substances and select the correct answer using the code given below the lists

List – I Substances		List – II Composition	
(A)	Plaster of paris	(i)	$\text{CaSO}_4 \cdot 2\text{H}_2\text{O}$
(B)	Epsomite	(ii)	$\text{CaSO}_4 \cdot 1/2\text{H}_2\text{O}$
(C)	Kieserite	(iii)	$\text{MgSO}_4 \cdot \text{H}_2\text{O}$
(D)	Gypsum	(iv)	$\text{CaSO}_4$

Code:

	(a)	(b)	(c)	(d)
(1)	(iii)	(iv)	(i)	(ii)
(2)	(ii)	(iii)	(iv)	(i)
(3)	(i)	(ii)	(iii)	(iv)
(4)	(iv)	(iii)	(ii)	(i)

Ans. (2)

24. The pairs of species of oxygen and their magnetic behaviours are noted below. Which of the following presents the correct description?

- (1)  $O_2^-$ ,  $O_2^{2-}$  – Both diamagnetic
- (2)  $O^+$ ,  $O_2^{2-}$  – Both paramagnetic
- (3)  $O_2^+$ ,  $O_2$  – Both paramagnetic
- (4)  $O$ ,  $O_2^{2-}$  – Both paramagnetic

Ans. (3)

25. Consider the reaction

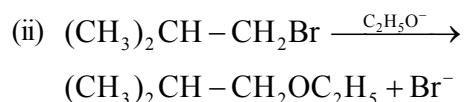
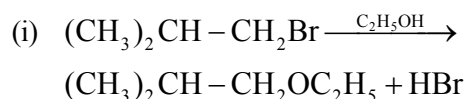

The mechanisms of reaction (i) and (ii) are respectively

- (1)  $S_{N1}$  and  $S_{N2}$
- (2)  $S_{N1}$  and  $S_{N1}$
- (3)  $S_{N2}$  and  $S_{N2}$
- (4)  $S_{N2}$  and  $S_{N1}$

Ans. (3)

26. Which of the following complex compounds will exhibit highest paramagnetic behaviour?

- (1)  $[Ti(NH_3)_6]^{3+}$
- (2)  $[Cr(NH_3)_6]^{3+}$
- (3)  $[Co(NH_3)_6]^{3+}$
- (4)  $[Zn(NH_3)_6]^{2+}$

(At. No. Ti = 22, Cr = 24, Co = 27, Zn = 30)

Ans. (2)

27. 200 mL of an aqueous solution of a protein contain its 1.26 g. The Osmotic pressure of this solution at 300 K is found to be  $2.57 \times 10^{-3}$  bar. The molar mass of protein will be ( $R = 0.083 \text{ L bar mol}^{-1} \text{ K}^{-1}$ )

- (1)  $51022 \text{ g mol}^{-1}$
- (2)  $122044 \text{ g mol}^{-1}$
- (3)  $31011 \text{ g mol}^{-1}$
- (4)  $61038 \text{ g mol}^{-1}$

Ans. (4)

28. Which of the following oxide is amphoteric?

- (1)  $SnO_2$
- (2)  $CaO$
- (3)  $SiO_2$
- (4)  $CO_2$

Ans. (1)

29. The following reactions take place in the blast furnace in the preparation of impure iron. Identify the reaction pertaining to the formation of the slag.

- (1)  $Fe_2O_3(s) + 3CO(g) \rightarrow 2Fe(l) + 3CO_2(g)$
- (2)  $CaCO_3(s) \rightarrow CaO(s) + CO_2(g)$
- (3)  $CaO(s) + SiO_2(s) \rightarrow CaSiO_3(s)$
- (4)  $2C(s) + O_2(g) \rightarrow 2CO(g)$

Ans. (3)

30. An organic compound 'A' on treatment with  $NH_3$  give 'B', which on heating gives 'C'. 'C' when treated with  $Br_2$  in the presence of  $KOH$  produces ethylamine. Compound 'A' is

- (1)  $CH_3COOH$
- (2)  $CH_3CH_2CH_2COOH$
- (3)  $CH_3-\underset{\substack{| \\ CH_3}}{CH}COOH$
- (4)  $CH_3CH_2COOH$

Ans. (4)

## BIOLOGY

31. The technique called, gamete *intrafallopian transfer* (GIFT) is recommended for those females :
- (1) who cannot produce an ovum
  - (2) who cannot retain the foetus inside uterus
  - (3) whose cervical canal is too narrow to allow passage for the sperms
  - (4) who cannot provide suitable environment for fertilization

**Ans.** (1)

32. Which one of the following is a possibility for most of us in regard to breathing, by making a *conscious effort* ?

- (1) One can breathe out air totally without
- (2) One can breathe out air through eustachian tubes by closing both the nose and the mouth.
- (3) One can consciously breathe in and breathe out by moving the diaphragm alone, without moving the ribs at all.
- (4) The lungs can be made fully empty by forcefully breathing out all air from them

**Ans.** (3)

33. *Bacillus thuringiensis* forms protein crystals which contain insecticidal protein.

This protein :

- (1) binds with epithelial cells of midgut of the insect pest ultimately killing it
- (2) is coded by several genes including the gene *cry*
- (3) is activated by acid pH of the foregut of the insect pest.
- (4) does not kill the carrier bacterium which is itself resistant to this toxin

**Ans.** (1)

34. Which one of the following pairs is *wrongly* matched while the remaining three are correct ?

- (1) *Penicillium* - Conidia
- (2) Water hyacinth - Runner
- (3) *Bryophyllum* - Leaf buds
- (4) *Agave* - Bulbils

**Ans.** (2)

35. Which one of the following diagrams represents the placentation in *Dianthus* ?

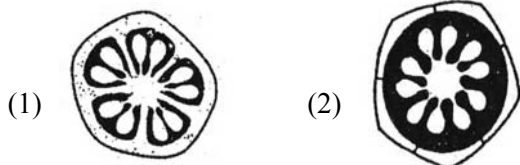

(1)

(2)

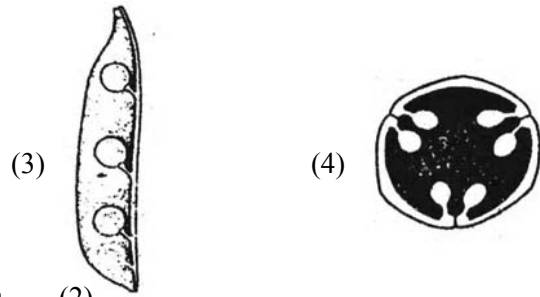

(3)

(4)

**Ans.** (2)

36. Which one of the following statements is **totally wrong** about the occurrence of *notochord*, while the other three are correct?

- (1) It is present only in larval tail in Ascidians
- (2) It is replaced by a vertebral column in adult frog
- (3) It is absent throughout life in humans from the very beginning
- (4) It is present throughout life in *Amphioxus*

**Ans.** (3)

37. Which one of the following animals may occupy more than one trophic levels in the same ecosystem at the same time ?

- (1) Sparrow
- (2) Lion
- (3) Goat
- (4) Frog

**Ans.** (1)

38. Both, hydrarch and xerarch successions lead to :

- (1) Medium water conditions
- (2) Xeric conditions
- (3) Highly dry conditions
- (4) Excessive wet conditions

**Ans.** (1)

39. What happens during fertilisation in humans after many sperms reach close to the ovum ?

- (1) Secretions of acrosome helps one sperm enter cytoplasm of ovum through zona pellucida
- (2) All sperms except the one nearest to the ovum lose their tails
- (3) Cells of corona radiata trap all the sperms except one.
- (4) Only two sperms nearest the ovum penetrate zona pellucida

**Ans.** (1)

40. About which day in a normal human menstrual cycle does rapid secretion of LH (popularly called LH-surge) normally occurs ?

- (1) 14<sup>th</sup> day
- (2) 20<sup>th</sup> day
- (3) 5<sup>th</sup> day
- (4) 11<sup>th</sup> day

**Ans.** (1)

41. The cells lining the blood vessels belong to the category of :

- (1) Smooth muscle tissue
- (2) Squamous epithelium
- (3) Columnar epithelium
- (4) Connective tissue

**Ans.** (2)

42. The pathogen *Microsporium* responsible for ringworm disease in humans belongs to the same Kingdom of organisms as that of :

- (1) *Taenia*, a tapeworm
- (2) *Wuchereria*, a filarial worm
- (3) *Rhizopus*, a mould
- (4) *Ascaris*, a round worm

**Ans.** (3)

43. The figure below shows the structure of a mitochondrion with its four parts labelled (A), (B), (C) and (D). Select the part correctly matched with its function.

- (1) Part (D) : Outer membrane – gives rise to inner membrane by splitting
- (2) Part (B) : Inner membrane – forms infoldings called cristae
- (3) Part (C) : Cristae – possess single circular DNA molecule and ribosomes
- (4) Part (A) : Matrix – major site for respiratory chain enzymes

**Ans.** (2)

44. Read the following statement having two blanks (A and B) :

“A drug used for (A) patients is obtained from a species of the organism (B).”

The one *correct* option for the two blanks is :

- | <b>Blank - A</b>     | <b>Blank - B</b>   |
|----------------------|--------------------|
| (1) Heart            | <i>Penicillium</i> |
| (2) Organ-transplant | <i>Trichoderma</i> |
| (3) Swine flu        | <i>Monascus</i>    |
| (4) AIDS             | <i>Pseudomonas</i> |

**Ans.** (2)

45. Silencing of mRNA has been used in producing transgenic plants resistant to :

- (1) Bollworms
- (2) Nematodes
- (3) White rusts
- (4) Bacterial blights

**Ans.** (2)

46. At metaphase, chromosomes are attached to the spindle fibres by their :

- (1) Satellites
- (2) Secondary constrictions

(3) Kinetochores

(4) Centromere

**Ans.** (3)

47. Consider the following statements (A-D) about organic farming :

- (A) Utilizes genetically modified crops like Bt cotton
  - (B) Uses only naturally produced inputs like compost
  - (C) Does not use pesticides and urea
  - (D) Produces vegetables rich in vitamins and minerals
- Which of the above statements are **correct** ?

- (1) (B), (C) and (D)
- (2) (C) and (D) only
- (3) (B) and (C) only
- (4) (A) and (B) only

**Ans.** (1)

48. One of the constituents of the pancreatic juice while poured into the duodenum in humans, is :

- (1) Trypsinogen
- (2) Chymotrypsin
- (3) Trypsin
- (4) Enterokinase

**Ans.** (1)

49. Frogs differ from humans in possessing

- (1) paired cerebral hemispheres
- (2) hepatic portal system
- (3) nucleated red blood cells
- (4) thyroid as well as parathyroid

**Ans.** (3)

50. Which one of the following options gives the **correct** matching of a disease with its causative organism and mode of infection.

	Disease	Causative Organisms	Mode of Infection
(1)	Typhoid	<i>Salmonella typhi</i>	with inspired air
(2)	Pneumonia	<i>Streptococcus pneumoniae</i>	Droplet infection
(3)	Elephantiasis	<i>Wuchereria bancrofti</i>	With infected water and food
(4)	Malaria	<i>Plasmodium vivax</i>	Bite of male <i>Anopheles</i> mosquito

**Ans.** (2)

51. Function of companion cells is :

- (1) Providing energy to sieve elements for active transport
- (2) Providing water to phloem
- (3) Loading of sucrose into sieve elements by passive transport
- (4) Loading of sucrose into sieve elements

**Ans.** (4)

52. Test cross in plants or in *Drosophila* involves crossing:

- (1) between two genotypes with recessive trait
- (2) between two  $F_1$  hybrids
- (3) the  $F_1$  hybrid with a double recessive genotype.
- (4) between two genotypes with dominant trait

**Ans.** (3)

53. Some vascular bundles are described as open because these :

- (1) are surrounded by pericycle but no andodermis
- (2) are capable of producing secondary xylem and phloem
- (3) possess conjunctive tissue between xylem and phloem
- (4) are not surrounded by pericycle

**Ans.** (2)

54. In mitochondria, protons accumulate in the :

- (1) Outer membrane
- (2) Inner membrane
- (3) Intermembrane space
- (4) Matrix

**Ans.** (3)

55. The breakdown of detritus into smaller particles by earthworm is a process called :

- (1) Humification
- (2) Fragmentation
- (3) Mineralisation
- (4) Catabolism

**Ans.** (2)

56. Whorled, simple leaves with reticulate venation are present in :

- (1) *Calotropis*
- (2) Neem
- (3) China Rose
- (4) *Alstonia*

**Ans.** (4)

57. Sweet potato is homologous to :

- (1) Potato
- (2) Colocasia
- (3) Ginger
- (4) Turnip

**Ans.** (4)

58. The unequivocal proof of DNA as the genetic material came from the studies on a :

- (1) Bacterium
- (2) Fungus
- (3) Viroid
- (4) Bacterial virus

**Ans.** (4)

59. Consider the following four statements whether they are correct or wrong :

- (A) The sporophyte in liverworts is more elaborate than that in mosses
- (B) *Salvinia* is heterosporous
- (C) The life-cycle in all seed-bearing plants is diplontic
- (D) In *Pinus* male and female cones are borne on different trees

The two *wrong* statements together are :

- (1) Statements (A) and (C)
- (2) Statements (A) and (D)
- (3) Statements (B) and (C)
- (4) Statements (A) and (B)

**Ans.** (2)

60. Consider the following four statements (A-D) related to the common frog *Rana tigrina*, and select the correct option stating which ones are true (T) and which ones are false (F).

**Statements :**

- (A) On dry land it would die due to lack of  $O_2$  if its mouth is forcibly kept closed for a few days.
- (B) It has four-chambered heart
- (C) On dry land it turns uricotelic from v ureotelic
- (D) Its life-history is carried out in pond water

**Options :**

- |     | (A) | (B) | (C) | (D) |
|-----|-----|-----|-----|-----|
| (1) | T   | F   | F   | T   |
| (2) | T   | T   | F   | F   |
| (3) | F   | F   | T   | T   |
| (4) | F   | T   | T   | F   |

**Ans.** (1)

61. In Kranz anatomy, the bundle sheath cells have :

- (1) thin walls, many intercellular spaces and no chloroplasts
- (2) thick walls, no intercellular spaces and large number of chloroplasts
- (3) thin walls, no intercellular spaces and several chloroplasts
- (4) thick walls, many intercellular spaces and few chloroplasts

**Ans.** (2)

62. Given below is the ECG of a normal human. Which one of its components is correctly interpreted below?

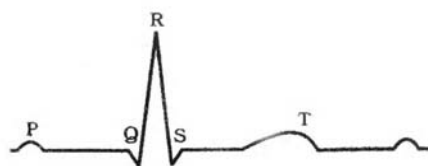

- (1) Complex QRS - One complete pulse

- (2) Peak T - Initiation of total cardiac contraction  
 (3) Peak P and Peak R together - systolic and diastolic blood pressures  
 (4) Peak P - Initiation of left atrial contraction only

**Ans.** (1)

63. Which one of the following structures in Pheretima is correctly matched with its function ?

- (1) Clitellum - secretes cocoon  
 (2) Gizzard - absorbs digested food  
 (3) Setae - defence against predators  
 (4) Typhlosole - storage of extra nutrients

**Ans.** (1)

64. *Selaginella* and *Salvinia* are considered to represent a significant step toward evolution of seed habit because :

- (1) Female gametophyte is free and gets dispersed like seeds.  
 (2) Female gametophyte lacks archegonia.  
 (3) Megaspores possess endosperm and embryo surrounded by seed coat.  
 (4) Embryo develops in female gametophyte which is retained on parent sporophyte.

**Ans.** (4)

65. Bulk of carbon dioxide (CO<sub>2</sub>) released from body tissues into the blood is present as :

- (1) bicarbonate in blood plasma and RBCs.  
 (2) free CO<sub>2</sub> in blood plasma  
 (3) 70% carbamino-haemoglobin and 30% as bicarbonate  
 (4) carbamino-haemoglobin in RBCs

**Ans.** (1)

66. In angiosperms, functional megaspore develops into:

- (1) Embryo sac (2) Ovule  
 (3) Endosperm (4) Pollen sac

**Ans.** (1)

67. Consider the following statements (A)-(D) each with one or two blanks.

- (A) Bears go into (1) during winter to (2) cold weather.  
 (B) A conical age pyramid with a broad base represents (3) human,, population.  
 (C) A wasp pollinating a fig flower is an example of (4).  
 (D) An area with high levels of species richness is known as (5).

Which one of the following options, gives the correct fill ups for the respective blank numbers from (1) to (5) in the statements ?

- (1) (3) - stable (4) - commensalism, (5) marsh  
 (2) (1) - aestivation, (2) - escape, (3) - stable?  
 (4) - mutualism

- (3) (3) - expanding, (4) - commensalism,  
 (5) - biodiversity park  
 (4) (1) - hibernation, (2) - escape, (3) - expanding,  
 (5) hot spot

**Ans.** (4)

68. What is common between vegetative reproduction and Apomixis ?

- (1) Both are applicable to only dicot  
 (2) Both bypass the flowering phase  
 (3) Both occur round the year  
 (4) Both produces progeny identical to the parent

**Ans.** (4)

69. Common cold is not cured by antibiotics because it is:

- (1) caused by a virus  
 (2) caused by a Gram-positive bacterium  
 (3) caused by a Gram-negative bacterium  
 (4) not an infectious disease

**Ans.** (1)

70. Which one of the following is not an essential mineral element for plants while the remaining three are ?

- (1) Iron (2) Manganese  
 (3) Cadmium (4) Phosphorus

**Ans.** (3)

71. Biodiversity of a geographical region represents :

- (1) Endangered species found in the region.  
 (2) The diversity in the organisms living in the region.  
 (3) Genetic diversity present in the dominant species of the region.  
 (4) Species endemic to the region.

**Ans.** (2)

72. Which one of the following is not considered as a part of the endomembrane system ?

- (1) Golgi complex (2) Peroxisome  
 (3) Vacuole (4) Lysosome

**Ans.** (2)

73. Which one of the following correctly represents the normal adult human dental formula ?

- (1)  $\frac{3}{3}, \frac{1}{1}, \frac{3}{2}, \frac{1}{1}$  (2)  $\frac{2}{2}, \frac{1}{1}, \frac{3}{2}, \frac{3}{3}$   
 (3)  $\frac{2}{2}, \frac{1}{1}, \frac{2}{2}, \frac{3}{3}$  (4)  $\frac{3}{3}, \frac{1}{1}, \frac{3}{3}, \frac{3}{3}$

**Ans.** (3)

74. Select the correct statement with respect to diseases and immunisation :

- (1) If due to some reason B-and T-lymphocytes are damaged, the body will not produce antibodies against a pathogen.  
 (2) Injection of dead / inactivated pathogens causes passive immunity



- (3) Certain protozoans have been used to mass produce hepatitis B vaccine.  
 (4) Injection of snake antivenom against snake bite is an example of active immunisation.

Ans. (1)

75. The figure shows four animals (a), (b), (c) and (d). Select the correct answer with respect to a common characteristics of two of these animals.

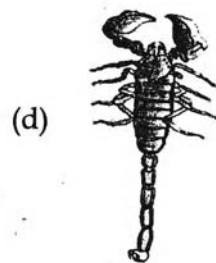
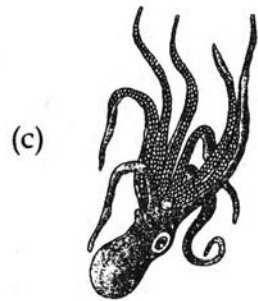
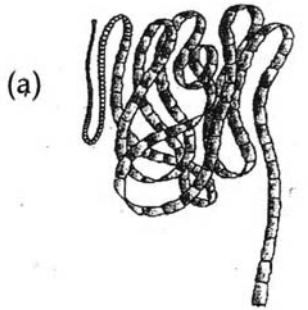

- (1) (a) and (d) respire mainly through body wall  
 (2) (b) and (c) show radial symmetry  
 (3) (a) and (b) have cnidoblasts for self-defence  
 (4) (c) and (d) have a true coelom

Ans. (4)

76. In history of biology, human genome project led to the development of :

- (1) Biotechnology                      (2) Biomonitoring  
 (3) Bioinformatics                      (4) Biosystematics

Ans. (3)

77. Which one of the following conditions of the zygotic cell would lead to the birth of a normal human female, child ?

- (1) two X chromosomes  
 (2) only one Y chromosome  
 (3) only one X chromosome  
 (4) one X and one Y chromosome

Ans. (1)

78. Which one of the following is essential for photolysis of water ?

- (1) Manganese                      (2) Zinc  
 (3) Copper                              (4) Boron

Ans. (1)

79. Which one of the following techniques made it possible to genetically engineer living Organisms ?

- (1) Recombinant DNA techniques  
 (2) X-ray diffraction  
 (3) Heavier isotope labelling  
 (4) Hybridization

Ans. (1)

80. Ureters act as urinogenital ducts in :

- (1) human males  
 (2) human females  
 (3) frog's both males and females  
 (4) frog's males

Ans. (4)

81. The type of muscles present in our :

- (1) *heart* are involuntary and unstriated / smooth muscles  
 (2) *intestine* are striated and involuntary  
 (3) *thigh* are striated and voluntary  
 (4) upper arm are smooth muscle fibres fusiform in shape

Ans. (3)

82. Read the following four statements (A-D) about certain mistakes in two of them.

- (A) The first transgenic buffalo, Rosie produced milk which was human alpha-lactalbumin enriched.  
 (B) Restriction enzymes are used in isolation of DNA from the macro-molecules.  
 (C) Downstream processing is one of the steps of R-DNA technology  
 (D) Disarmed pathogen vectors are also used in transfer of R-DNA into the host

Which are the two statements having mistakes ?

- (1) Statements (B) and (C)  
 (2) Statements (C) and (D)  
 (3) Statements (A) and (C)  
 (4) Statements (A) and (B)

Ans. (4)

83. The 24 hour (diurnal) rhythm of our body such as the sleep-wake cycle is regulated by the hormone :

- (1) calcitonin (2) prolactin  
(3) adrenaline (4) melatonin

**Ans.** (4)

84. Guttation is the result of :

- (1) Diffusion (2) Transpiration  
(3) Osmosis (4) Root pressure

**Ans.** (4)

85. Examine the figure given below and select the right option giving all the four parts (a, b, c and d) correctly identified.

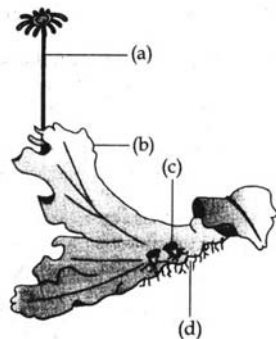

- |                     |                |            |          |
|---------------------|----------------|------------|----------|
| (a)                 | (b)            | (c)        | (d)      |
| (1) Archegoniophore | Female thallus | Gemma-cup  | Rhizoids |
| (2) Archegoniophore | Female thallus | Bud        | Foot     |
| (3) Seta            | Sporophyte     | Protone-ma | Rhizoids |
| (4) Antheridiophore | Male thallus   | Globule    | Roots    |

**Ans.** (1)

86. Three of the following pairs of the human skeletal parts are correctly matched with their respective inclusive skeletal category and one pair is not matched. Identify the non-matching pair.

**Pairs of skeletal parts**      **Category**

- |                                 |                |
|---------------------------------|----------------|
| (1) Sternum and Ribs            | Axial skeleton |
| (2) Clavicle and Glenoid cavity | Pelvic girdle  |

- (3) Humerus and ulna      Appendicular skeleton  
(4) Malleus and stapes      Ear ossicles

**Ans.** (2)

87. Which one of the following aspects is an exclusive characteristic of living things ?

- (1) Isolated metabolic reactions occur in vitro  
(2) Increase in mass from inside only  
(3) Perception of events happening in the environment and their memory  
(4) Increase in mass by accumulation of material both on surface as well as internally

**Ans.** (2)

88. "Good ozone" is found in the

- (1) Mesosphere (2) Troposphere  
(3) Stratosph (4) Ionosphere

**Ans.** (3)

89. Which one of the following is a wrong matching of a microbe and its industrial product, while the remaining three are correct ?

- (1) Yeast - statins  
(2) Acetobacter aceti - acetic acid  
(3) Clostridium butylicum - lactic acid  
(4) Aspergillus niger - citric acid

**Ans.** (3)

90. The logistic population growth is expressed by the equation:

$$(1) \frac{dN}{dt} = Nr \left( \frac{K - N}{K} \right)$$

$$(2) \frac{dN}{dt} = rN \left( \frac{K - N}{K} \right)$$

$$(3) \frac{dN}{dt} = rN$$

$$(4) \frac{dN}{dt} = rN \left( \frac{N - K}{N} \right)$$

**Ans.** (2)

## PHYSICS

91. Two identical piano wires, kept under the same tension  $T$  have a fundamental frequency of 600 Hz. The fractional increase in the tension of one of the wires which will lead to occurrence of 6 beats/s when both the wires oscillate together would be :

- (1) 0.02                      (2) 0.03  
(3) 0.04                      (4) 0.01

Ans. (1)

92. In the following figure, the diodes which are forward biased, are :

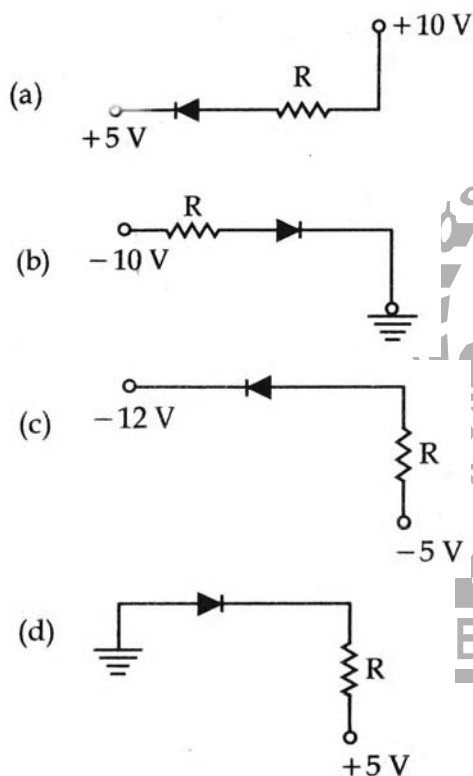

- (1) (c) only                      (2) (c) and (a)  
(3) (b) and (d)                      (4) (a), (b) and (d)

Ans. (2)

93. The threshold frequency for a photosensitive metal is  $3.3 \times 10^{14}$  Hz. If light of frequency  $8.2 \times 10^{14}$  Hz is incident on this metal, the cut-off voltage for the photoelectric emission is nearly :

- (1) 2V                          (2) 3V  
(3) 5V                          (4) 1V

Ans. (2)

94. A galvanometer of resistance,  $G$ , is shunted by a resistance  $S$  ohm. To keep the main current in the circuit unchanged, the resistance to be put in series

with the galvanometer is :

- (1)  $\frac{S^2}{(S+G)}$                       (2)  $\frac{SG}{(S+G)}$   
(3)  $\frac{G^2}{(S+G)}$                       (4)  $\frac{G}{(S+G)}$

Ans. (3)

95. A square loop, carrying a steady current  $I$ , is placed in a horizontal plane near a long straight conductor carrying a steady current  $I_1$  at a distance  $d$  from the conductor as shown in figure. The loop will experience:

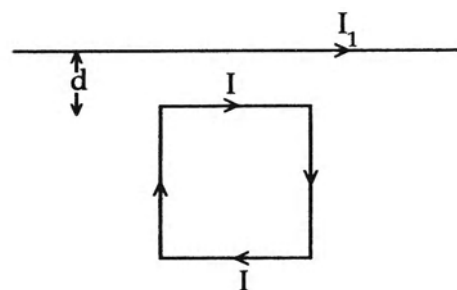

- (1) a net repulsive force away from the conductor  
(2) a net torque acting upward perpendicular to the horizontal plane  
(3) a net torque acting downward normal to the horizontal plane  
(4) a net attractive force towards the conductor

Ans. (4)

96. A thermocouple of negligible resistance produces an e.m.f. of  $40 \mu\text{V}/^\circ\text{C}$  in the linear range of temperature. A galvanometer of resistance 10 ohm whose sensitivity is  $1 \mu\text{A}/\text{div}$ , is employed with the thermocouple. The smallest value of temperature difference that can be detected by the system will be:

- (1)  $0.5^\circ\text{C}$                       (2)  $1^\circ\text{C}$   
(3)  $0.1^\circ\text{C}$                       (4)  $0.25^\circ\text{C}$

Ans. (4)

97. The r.m.s. value of potential difference  $V$  shown in the figure is :

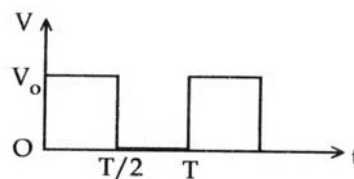

(1)  $V_0$  (2)  $V_0/\sqrt{2}$

(3)  $V_0/2$  (4)  $V_0/\sqrt{3}$

Ans. (2)

98. A coil has resistance 30 ohm and inductive reactance 20 Ohm at 50 Hz frequency. If an ac source, of 200 volt, 100 Hz, is connected across the coil, the current in the coil will be :

(1) 4.0 A (2) 8.0 A

(3)  $\frac{20}{\sqrt{13}}$  A (4) 2.0 A

Ans. (1)

99. A particle of mass  $m$  is thrown upwards from the surface of the earth, with a velocity  $u$ . The mass and the radius of the earth are, respectively,  $M$  and  $R$ .  $G$  is gravitational constant and  $g$  is acceleration due to gravity on the surface of the earth. The minimum value of  $u$  so that the particle does not return back to earth, is :

(1)  $\sqrt{\frac{2GM}{R}}$

(2)  $\sqrt{\frac{2gM}{R^2}}$

(3)  $\sqrt{2gR^2}$

(4)  $\sqrt{\frac{2GM}{R^2}}$

Ans. (1)

100. Pure Si at 500 K has equal number of electron ( $n_e$ ) and hole ( $n_h$ ) concentrations of  $1.5 \times 10^{16} \text{ m}^{-3}$ . Doping by indium increases  $n_h$  to  $4.5 \times 10^{22} \text{ m}^{-3}$ . The doped semiconductor is of:

(1) n - type with electron concentration  $n_e = 5 \times 10^{22} \text{ m}^{-3}$ (2) p - type with electron concentration  $n_e = 2.5 \times 10^{10} \text{ m}^{-3}$ (3) n - type with electron concentration  $n = 2.5 \times 10^{23} \text{ m}^{-3}$ (4) p - type having electron concentrations  $n_e = 5 \times 10^9 \text{ m}^{-3}$ 

Ans. (4)

101. Charge  $q$  is uniformly spread on a thin ring of radius  $R$ . The ring rotates about its axis with a uniform frequency  $f$  Hz. The magnitude of magnetic induction at the center of the ring is :

(1)  $\frac{\mu_0 q f}{2R}$

(2)  $\frac{\mu_0 q}{2fR}$

(3)  $\frac{\mu_0 q}{2\pi f R}$

(4)  $\frac{\mu_0 q f}{2\pi R}$

Ans. (1)

102. A zener diode, having breakdown voltage equal to 15 V, is used in a voltage regulator circuit shown in figure. The current through the diode is :

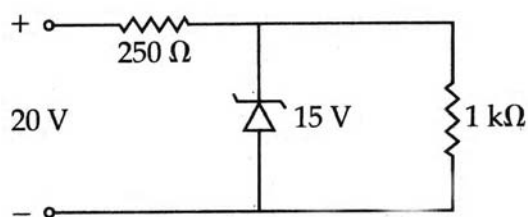

(1) 10 mA

(2) 15 mA

(3) 20 mA

(4) 5 mA

Ans. (4)

103. A particle covers half of its total distance with speed  $v_1$  and the rest half distance with speed  $v_2$ . Its average speed during the complete journey is :

(1)  $\frac{v_1 v_2}{v_1 + v_2}$

(2)  $\frac{2v_1 v_2}{v_1 + v_2}$

(3)  $\frac{v_1^2 v_2^2}{v_1^2 + v_2^2}$

(4)  $\frac{v_1 + v_2}{2}$

Ans. (2)

104. The electric potential  $V$  at any point  $(x, y, z)$ , all in meters in space is given by  $V = 4x^2$  volt. The electric field at the point  $(1, 0, 2)$  in volt/meter, is :

(1) 8 along positive X-axis

(2) 16 along negative X-axis

(3) 16 along positive X-axis

(4) % along negative X-axis

Ans. (4)

105. A short bar magnet of magnetic moment  $0.4 \text{ J T}^{-1}$  is placed in a uniform magnetic field of 0.16 T. The magnet is in stable equilibrium when the potential energy is :

(1)  $-0.064 \text{ J}$

(2) zero

(3)  $-0.082 \text{ J}$

(4)  $0.064 \text{ J}$

Ans. (1)

106. A thin prism of angle  $15^\circ$  made of glass of refractive index  $\mu_1 = 1.5$  is combined with another prism of glass of refractive index ( $\mu_2 = 1.75$ ). The combination of the prisms produces dispersion without deviation. The angle of the second prism should be :

- (1)  $7^\circ$  (2)  $10^\circ$   
 (3)  $12^\circ$  (4)  $5^\circ$

Ans. (2)

107. A conveyor belt is moving at a constant speed of 2 m/s. A box is gently dropped on it. The coefficient of friction between them is  $\mu = 0.5$ . The distance that the box will move relative to belt before coming to rest on it, taking  $g = 10 \text{ ms}^{-2}$

- (1) 1.2m (2) 0.6 m  
 (3) zero (4) 0.4 m

Ans. (4)

108. A mass of diatomic gas ( $\gamma = 1.4$ ) at a pressure of 2 atmospheres is compressed adiabatically so that its temperature rises from  $27^\circ\text{C}$  to  $927^\circ\text{C}$ . The pressure of the gas in the final state is :

- (1) 28 atm (2) 68.7 atm  
 (3) 256 atm (4) 8 atm

Ans. (3)

109. A mass  $m$  moving horizontally (along the  $x$ -axis) with velocity  $v$  collides and sticks to a mass of  $3m$  moving vertically upward (along the  $y$ -axis) with velocity  $2v$ . The final velocity of the combination is :

- (1)  $\frac{1}{4}v\hat{i} + \frac{3}{2}v\hat{j}$  (2)  $\frac{1}{3}v\hat{i} + \frac{2}{3}v\hat{j}$   
 (3)  $\frac{2}{3}v\hat{i} + \frac{1}{3}v\hat{j}$  (4)  $\frac{3}{2}v\hat{i} + \frac{1}{4}v\hat{j}$

Ans. (1)

110. Two particles are oscillating along two close parallel straight lines side by side, with the same frequency and amplitudes. They pass each other, moving in opposite directions when their displacement is half of the amplitude. The mean positions of the two particles lie on a straight line perpendicular to the paths of the two particles. The phase difference is :

- (1) 0 (2)  $\frac{2\pi}{3}$

- (3)  $\pi$  (4)  $\frac{\pi}{6}$

Ans. (2)

111. A small mass attached to a string rotates on a frictionless table top as shown. If the tension in the string is increased by pulling the string causing the radius of the circular motion to decrease by a factor of 2, the kinetic energy of the mass will:

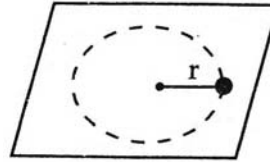

- (1) remain constant  
 (2) increase by a factor of 2  
 (3) increase by a factor of 4  
 (4) decrease by a factor of 2

Ans. (4)

112. The density of a material in CGS system of units is  $4 \text{ g/cm}^3$ . In a system of units in which unit of length is 10 cm and unit of mass is 100 g, the value of density of material will be :

- (1) 0.4 (2) 40  
 (3) 400 (4) 0.04

Ans. (2)

113. An electron in the hydrogen atom jumps from excited state  $n$  to the ground state. The wavelength so emitted illuminates a photosensitive material having work function  $2.75 \text{ eV}$ . If the stopping potential of the photoelectron is  $10 \text{ V}$ , then the value of  $n$  is:

- (1) 3 (2) 4  
 (3) 5 (4) 2

Ans. (4)

114. A particle of mass  $M$  is situated at the centre of a spherical shell of same mass and radius  $a$ . The magnitude of the gravitational potential at a point situated at  $a/2$  distance from the centre, will be :

- (1)  $\frac{2GM}{a}$  (2)  $\frac{3GM}{a}$   
 (3)  $\frac{4GM}{a}$  (4)  $\frac{GM}{a}$

Ans. (2)

115. Two radioactive nuclei P and Q, in a given sample decay into a stable nucleus R. At time  $t=0$ , number of P species are  $4N_0$  and that of Q are  $N_0$ . Half-life of P (for conversion to R) is 1 minute where as that of Q is 2 minutes. Initially there are no nuclei of R present in the sample. When number of nuclei of P and Q are equal, the number of nuclei of R present in the sample would be :

- (1)  $3N_0$                       (2)  $\frac{9N_0}{2}$   
 (3)  $\frac{5N_0}{2}$                       (4)  $2N_0$

Ans. (2)

116. A projectile is fired at an angle of  $45^\circ$  with the horizontal. Elevation angle of the projectile at its highest point as seen from the point of projection, is:

- (1)  $60^\circ$                       (2)  $\tan^{-1} \frac{1}{2}$   
 (3)  $\tan^{-1} \left( \frac{\sqrt{3}}{2} \right)$                       (4)  $45^\circ$

Ans. (2)

117. Out of the following which one is not a possible energy for a photon to be emitted by hydrogen atom according to Bohr's atomic model ?

- (1) 1.9 eV                      (2) 11.1 eV                      (1)  $\frac{3qQ}{8\pi \epsilon_0 a}$   
 (3) 13.6 eV                      (4) 0.65 eV                      (3) zero

Ans. (3)

118. The circuit shown in the figure, if the potential at point A is taken to be zero, the potential at point B is:

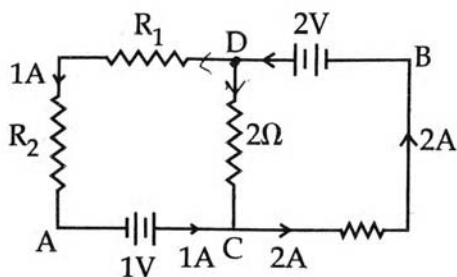

- (1)  $-1V$                       (2)  $+2V$   
 (3)  $-2V$                       (4)  $+1V$

Ans. (4)

119. A converging beam of rays is incident on a diverging lens. Having passed through the lens the rays intersect at a point 15 cm from the lens on the opposite side. If the lens is removed the point where the rays meet will move 5 cm closer to the lens. The focal length of the lens is :

- (1)  $-10\text{ cm}$                       (2)  $20\text{ cm}$   
 (3)  $-30\text{ cm}$                       (4)  $5\text{ cm}$

Ans. (2)

120. Three charges, each  $+q$ , are placed at the corners of an isosceles triangle ABC of sides BC and AC, 2a. D and E are the mid points of BC and CA. The work done in taking a charge Q from D to E is

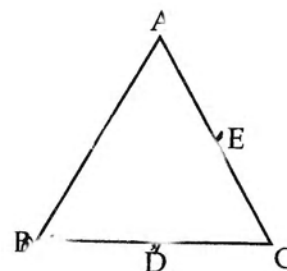

- (1)  $\frac{3qQ}{8\pi \epsilon_0 a}$                       (2)  $\frac{qQ}{4\pi \epsilon_0 a}$   
 (3) zero                      (4)  $\frac{3qQ}{4\pi \epsilon_0 a}$

Ans. (3)

